

DVB Terrestrial Broadcasting - 4

Peter Barnett, C.Eng.

peter.barnett@mandercom.co.uk

+44 1794 341053

Electronic programme guide

- Event Information Table – EIT – has two sub-tables:
 - EIT present/following (now/next)
 - EIT schedule for greater detail and duration
- Software in the receiver interprets and presents the information, but has the “look and feel” of the receiver manufacturer, not the broadcaster
- Broadcasters co-operate to produce EIT schedule data

Electronic programme guide

- EIT is not effectively compressed – requires relatively high bandwidth
- DVB has specified “Carriage and signalling of TV-Anytime information in DVB transport streams”, TS 102 323, which can provide richer data at lower bandwidth

Interactivity

- DVB-MHP (Multimedia Home Platform) is an open middleware system for interactive TV
- GEM (Globally Executable MHP) was developed to allow broad content compatibility across a range of delivery platforms, and is now the primary specification (over MHP)

Interactivity

- DVB-GEM (Globally Executable MHP) is the core of numerous interactive TV systems

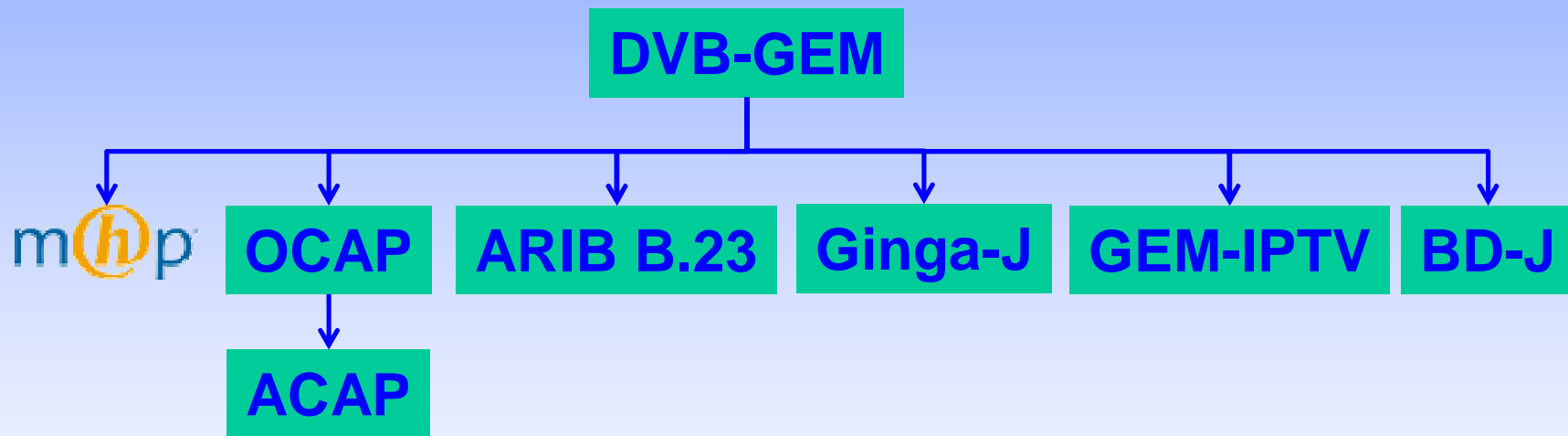

- MHP = DVB Multimedia Home Platform
- OCAP = OpenCable Application Platform (Cable Labs, USA) now called Tru2Way
- ACAP = Advanced Common Application Platform (ATSC, USA)
- ARIB B.23 = Application Execution Engine Platform for Digital Broadcasting (Japan)
- Ginga-J = Middleware for SBTVD (Brazil)
- BD-J = Blu-ray Disc Java

MHEG-5

- MHEG-5 is a language standardised in ETSI, and commonly used to describe interactive TV services
- Used in the UK and several other countries
- Further details at www.impala.org

Conditional Access

- CA provides:
 - Broadcaster revenue
 - A framework for marketing through addressability
- Supports:
 - Subscription services (tiered)
 - Pay Per View
 - Interactive services, e.g. shopping

Conditional Access

- DVB defined:
 - Common Scrambling Algorithm (unavailable...)
 - Simulcrypt, which allows co-operating operators to use a common control word with more than one CA system. The broadcaster can avoid being locked into one CA vendor.

Reception

- Antenna requirements depend on network design:
 - Rooftop antenna, typically at ~10m
 - Set-top antenna
 - Mobile (vehicle)
 - Hand held

Service degradation

Picture quality

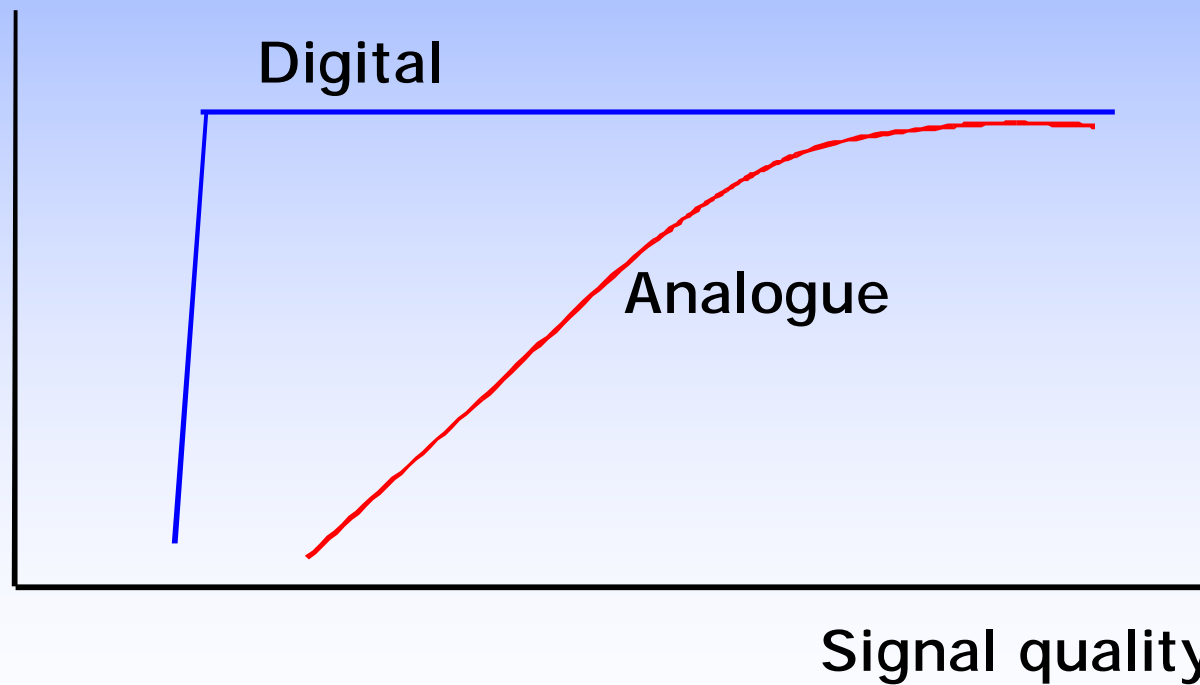

Rooftop antennas

- DVB-T is vulnerable to impulsive interference (I.I.)
- An antenna with a balun allows far less I.I. on the outer of the coax cable to get onto the inner
- The UK network is interference limited, and relies on rejection of signals from off-beam directions

Rooftop antennas

- The soft failure of analogue has allowed installers to fit large numbers of poorly designed antennas
- The Confederation of Aerial Industries has created a benchmarking scheme – see <http://www.cai.org.uk/information/benchmarking-scheme>

Set-top antennas

- Mandercom carried out a small survey for the UK government in 2005. Most were poor.
- A wider survey for consumers was subsequently carried out:
<http://www.ricability-digitaltv.org.uk/pages/test-reports/indoor-aerials.htm>

Set-top antennas

- Reflections indoor can produce signal cancellation over a large part of a channel.
- Experiments have shown that diversity reception helps, but consumer equipment with diversity has not been seen.

Indoor reception

- Suffers from
 - lack of height gain
 - building entry loss
 - Totalling 20-30dB, compared to external roof level

Mobile

- Various experiments and demonstrations have shown that mobile reception can be quite reliable.
- No real sign of business models that work.

Hand-held

- Transmitter networks for hand-held devices are dense (compare with cell phones) to lay down a high field strength due to
 - lack of height gain
 - building entry loss
 - lack of antenna gain

Impulsive Interference

- Primarily from house wiring and traffic
- For DVB-T, causes block errors on the picture, freeze-frames, audio mutes
- Greater effect at lower frequencies
- 8K threshold is theoretically 6dB higher than 2K
- Two entry routes: aerial, feeder

Impulsive interference

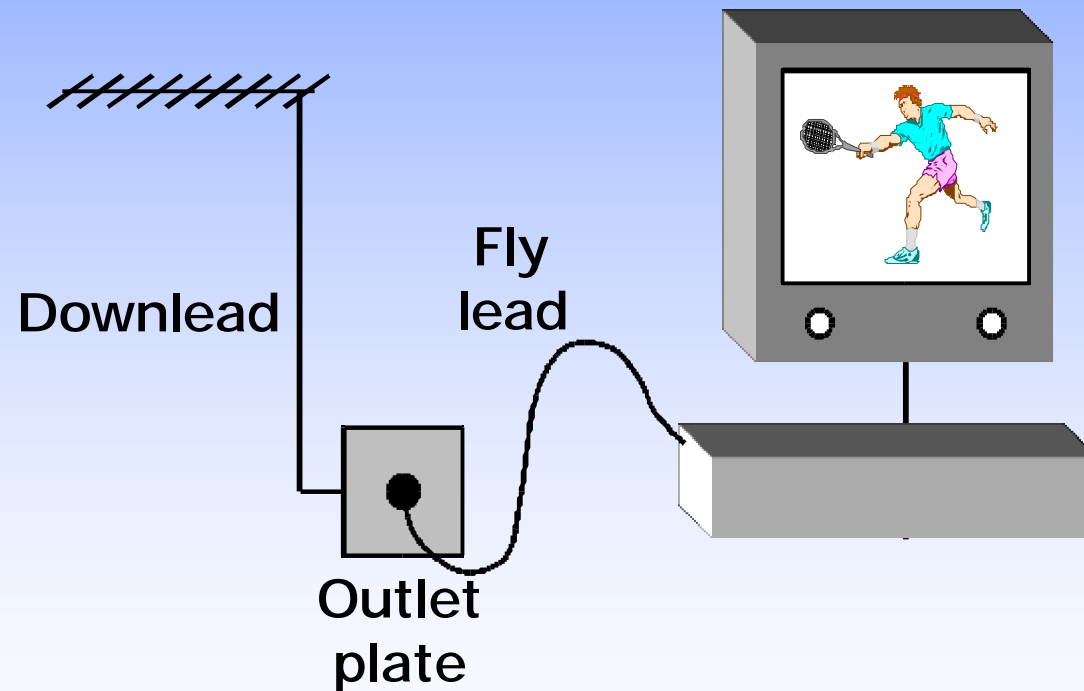

Master Antenna TV

- Used in blocks of apartments and groups of houses to avoid having many antennas
- Usually simple systems based on copper coaxial cable
- Can be designed to handle return channels
- Some fibre optic systems now appearing

MATV System

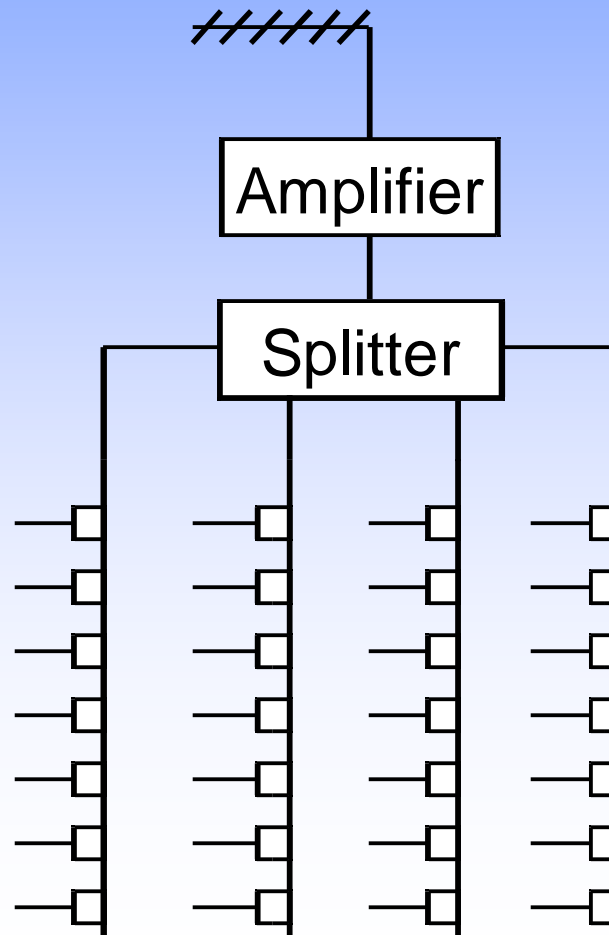

Integrated Reception System

- IRS provides both terrestrial UHF and satellite signals in housing blocks
- System acts as if user has own antenna and dish

IRS

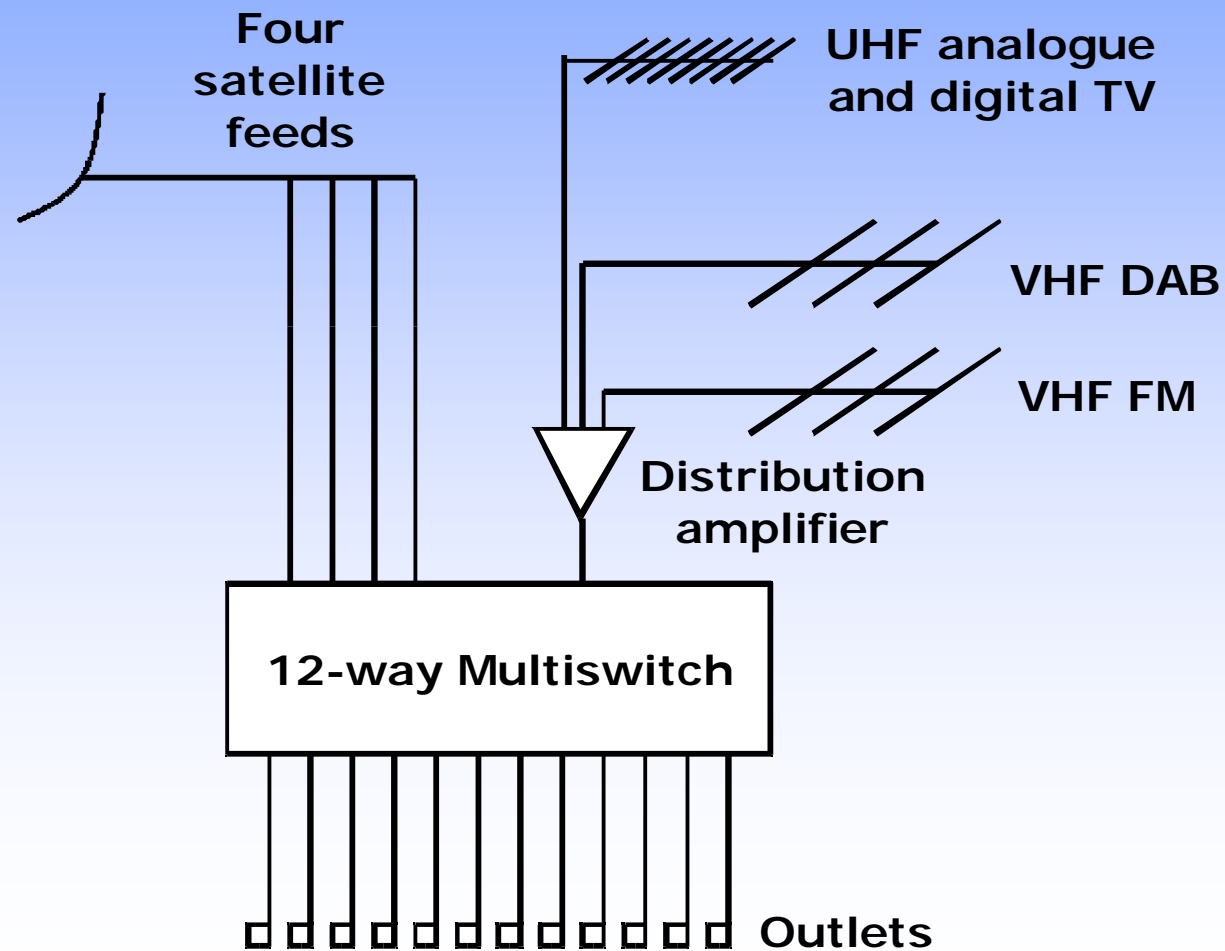

Receivers

- **Set-top Box, STB**
- **Personal Video Recorder, PVR**
(sometimes **Personal Digital Recorder, PDR**)
- **Integrated Digital TV**

Set-top Boxes

- In 1998 an STB was around £250. Today STBs are available in the UK from about £15
- Can use with existing analogue TV – provided it has a SCART (RF modulators are uncommon)
- Cheapest way of converting from analogue

Set-top Boxes

- DVB-T2 transmissions started in early 2010 in the UK, and now cover about 50% of households
- 14 products at service launch
- Now:
 - 4 STBs from £100 to £180
 - Many idTVs
 - 3 PVRs from £250 to £300

PVRs

- Two tuners and a hard disk
 - Record one programme while watching another
 - Pause live TV
 - Disk always more than 90% full!

Connected TV

- TV with Ethernet for connecting to the web
- HbbTV has created a specification
- Some manufacturers have own product
- UK's Digital TV Group is working on Connected TV with BBC's Canvas
- DVB is developing a strategy

Any questions?